Residential Districts

Introduction

The new zoning code will be structured so that each group of districts is organized in a separate chapter. Each of these chapters will include a common list of uses, other common standards, and a series of districts, each with its own dimensional standards. This draft also contains related elements that will end up in other sections, such as new definitions and standards for various uses.

Please note that:

- Material in italics (like this introduction) is not part of the Code text; these are annotations.
- Sidebars are also used for longer comments.
- Highlights in the text or sidebars indicate changes or questions.
- Illustrations depict minimum or typical dimensional standards but if there is a conflict with the text, the text governs. Some illustrations are regulatory, where others are “illustrative.”

Please also note that the format of this chapter is not the final format of the Code. All sections will be numbered and titled in a consistent manner, with input from the City Attorney. Also be aware that this is a first draft, and many additions and changes are likely following Committee review and public input.

General Provisions for Residential Districts

Permitted Yard Encroachments

The following structures or features are permitted in required yards. The letter “A” in the table indicates that the structure or feature is allowed anywhere in the required yard. A number indicates the maximum distance in feet that the structure or feature is allowed to extend into the yard.

Structure or Feature	All Yards	Front Yard	Side Yard	Rear Yard
Accessibility accommodations as specified in Section __	A			
Accessory sheds, toolrooms, doghouses, and similar buildings or structures				A
Air conditioning condensing unit			A	A
Arbors and trellises	A			
Awnings	A			
Basement storm doors providing access to below-grade stairs				A
Balconies				6
Bay windows, max. one story in height, see Section __		3	2	3
Chimneys, pipes	2			
Compost bins				3 from prop. line
Eaves and gutters	3	2	3	
Egress windows	minimum egress req.			
Decks, uncovered, elevated over 3' above adjacent ground level				6

Structure or Feature	All Yards	Front Yard	Side Yard	Rear Yard
Decks, uncovered, elevated not more than 3' above adjacent ground level				A
Fences, walls, hedges; see Section __	A			
Fire escapes			1/3 width of yard; up to 3 ft.	6
Flagpoles or garden ornaments	A			
Garages, detached, see Section __			A	A
Laundry drying equipment			A	A
Licensed radio towers <75' and receiving devices				A
Open porches		6		
Open on-street parking spaces, see Section [28.11(3)]	A			
Recreational equipment, minor	A			
Recreational equipment, major				A
Solar energy systems or devices	A			
Steps and platforms, uncovered, needed for building access. ^a		Note (a)		
Steps, below-grade, needed for access to basement entrances	A			
Swimming pools, hot tubs, whirlpools, or similar structures				3 ft. from prop. line
Wind energy systems or devices				

(a) Uncovered entrance platforms necessary to comply with current ingress and egress regulations may extend four (4) feet into the front yard setback area and shall be no wider than six (6) ft. and steps from the platform may extend into the setback area for the distance needed to meet minimum building code requirements for risers and treads. Replacement steps for porches may be as wide as the steps being replaced and may extend into the setback area for the distance needed to meet minimum building code requirements for risers and treads.

Accessory Buildings

- A. Maximum area per lot: Total area of accessory buildings measured at ground floor: ten percent (10%) of lot area but no more than one thousand (1,000) square feet. A larger total building area may be allowed by conditional use permit.
- B. Maximum percentage of rear yard: Accessory buildings may occupy a maximum of fifty percent (50%) of the area of the required rear yard.
- C. Maximum size of accessory building: No individual structure shall exceed eight hundred (800) square feet in size except by conditional use permit.
- D. Maximum height. The height of the principal building or fifteen (15) feet, whichever is lower. Taller buildings may be allowed by area exception, under Section ____.

E. Placement. Accessory buildings may be located in the following locations:

1. In a rear yard a minimum of 3 feet from any property line;
2. In a side yard if located behind the rear plane of the principal building, a minimum of 3 feet from any property line;
3. In the side or rear yard of a corner lot, a minimum distance from the street side lot line equal to the setback **required** for a principal building in the district;
4. In the rear yard of a reversed corner lot, no closer to the street side lot line than the front yard setback of the adjacent property, for the first 25 feet from the common property line. Beyond this distance, the minimum setback shall be equal to the setback **required** for a principal building in the district.

An accessory building may be placed outside of these limits only by area exception, where allowed under Section ____.

F. Shared garages. A detached garage may be constructed across a lot line by abutting property owners, anywhere a garage is **permitted within 3 feet of the lot line**, if: 1) there is a joint driveway leading to it; and 2) the property owners have an **approved and recorded** joint access and maintenance agreement relating to the shared garage.

G. Rear yard garage replacement. A detached garage located in a rear yard may be replaced within its existing setbacks *[in its existing location?]*, if: the replacement is within one year of demolition; the Zoning Department has verified the location and size of the existing or demolished garage; the enlarged structure does not exceed twenty-four (24) feet in length or width; and neither the width or length is increased by more than two (2) feet.

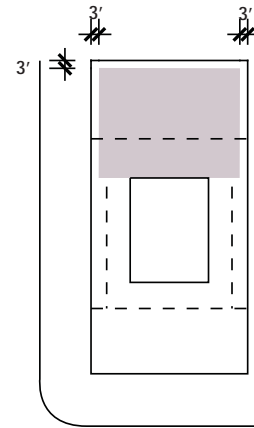

Accessory building on typical lot

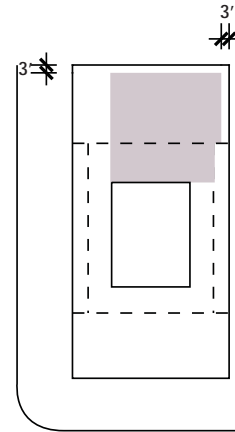

Accessory building on corner lot

Front Yard Setback Averaging

Where at least fifty (50) percent of any **block face** is built up with principal structures, the minimum front yard required for new structures is reduced to the built average setback of the existing structures. For structures set back more than the minimum front yard required in the district, the minimum district requirement shall be used in calculating the average. Porches and other encroachments into required yards shall not count towards the average. *[A different method will apply on Lakefront lots.]*

Residential Design Standards

All new development and major additions or remodels [threshold to be determined] within the residential districts shall comply with the following design standards:

A. Sidewall O set. In order to avoid the monotonous appearance of long unbroken building facades from streets or abutting properties, any portion of a building side wall located within 18' of the side lot line that exceeds 40' in depth shall be set back an additional 2" from the side lot line for every foot over 40 feet in depth.

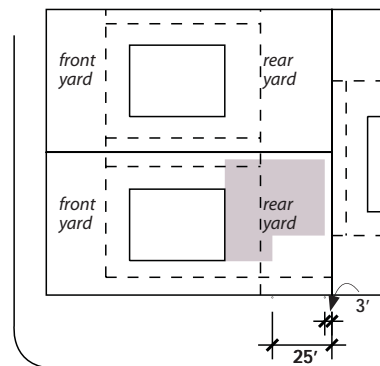

Accessory building on reverse corner lot

- B. Attached Garage Setback. In order to avoid the monotonous and pedestrian-unfriendly appearance of facades dominated by garage doors, any street-facing wall that contains an attached garage door may occupy no more than 50% of the width of that building façade, measured at grade. at portion of the façade that contains the garage door must be recessed at least 2' behind the remainder of the façade.

Nonresidential Design Standards

All new development and major additions threshold to be determined] within residential districts shall comply with the following design standards:

- A. Long Façade Articulation. In order to avoid the monotonous appearance of long unbroken building facades from streets or abutting properties, any portion of a building side wall that exceeds 40' in depth shall be set back an additional 2" from the side lot line for every foot over 40 feet in depth.
- B. Front Yard Setback. All building facades abutting any street shall be set back from the street lot line a minimum distance equal to the front yard setback required for that zoning district.
- C. Parking Location. In new construction, surface parking shall not be permitted between the front façade of any nonresidential building and the abutting street.

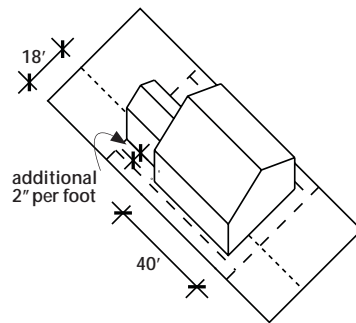

Sidewall Offset

Occupancy Restrictions

- A. A non-owner occupied dwelling unit located within the SR-C1-C3, the TR-C1-C3, the TR-E and the TR-P districts shall not include more than one roomer, with the following exception:
- B. In any district, up to four unrelated persons who have disabilities may live as a single housekeeping unit with up to two personal attendants.
- C. An owner-occupied dwelling unit, as defined in this ordinance, within any district may be occupied by a family and up to four roomers.

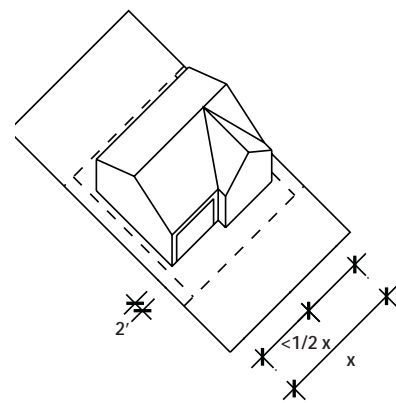

Attached garage setback

Height Measurements

In the case of alterations, additions, or replacement of existing buildings, height shall be measured from the natural grade prior to redevelopment. [see definition of "natural grade"]

Area Exceptions

Area exceptions shall be allowed in all Traditional Residential districts on zoning lots that meet one or more of the following requirements:

- A. Eligibility. To be eligible to apply for an area exception, a zoning lot must have been created prior to July 8, 1966, and any building or structure on the lot must have been constructed prior to that date. Additionally, the zoning lot must exhibit one or more of the following conditions:

The intent is to allow area exceptions in traditional residential areas, possibly with some exceptions, since these are the locations where this technique has been most beneficial in managing additions on small lots. Note the change regarding pre-1966 structures.

1. The lot is less than the minimum lot width requirement in the zoning district where it is located.
2. The lot is less than or equal to 100 feet in depth.
3. The lot is less than the minimum lot area required in the zoning district.
4. The structure proposed to be altered is nonconforming to current bulk requirements of the zoning district.
5. An adjacent lot has a structure that is nonconforming to current bulk requirements of the zoning district on the side towards the lot seeking an area exception.
6. The lot is adjacent to public right of way, a park, the rear yard of a reversed corner lot, or a railroad right of way.
7. The lot contains trees of the following minimum sizes that affect compliance within the current bulk requirements of the zoning district:
 - a. Deciduous trees with a trunk caliper measurement of twelve (12) or more inches.
 - b. Evergreen trees 20 or more feet in height.
8. The lot contains storm water drainage characteristics or a slope of at least 2 feet over 10 feet that affects compliance with the current bulk requirements of the zoning district.
9. The lot has a nonrectangular shape.
10. A recorded utility easement(s) on the lot would affect compliance with the current bulk requirements of the zoning district.

B. Minimum dimensional standards. Dimensional standards may be reduced by the Zoning Board of Appeals to the following, in compliance with the process and standards of Section ____.

Standard	Exception
Front Yard Setback	may be reduced to 10 feet
Side Yard Setback (one or two-story buildings)	may be reduced to 3 feet / 7 feet both sides
Reversed Corner Side Yard Setback	may be reduced to 3 feet
Side Yard Offset	may be waived
Rear Yard Setback	may be reduced to 10 feet
	15
Accessory Building Setback to Lot Line	may be reduced to 1 foot
Accessory Building Height	may be increased to 17 feet

Lakefront Development

The following regulation shall apply to all zoning lots that abut lakes within the City. New construction on lakefront lots shall meet the following standards.

Lakefront Yard Setback

The yard that abuts the lake, typically the rear yard, shall be referred to as the "lakefront yard." The minimum depth of the lakefront yard from the Ordinary High Water Line shall be calculated based on the average setback of the 5 developed lots or 300 feet on either side (whichever is less), or 30% of lot depth, whichever number is greater. Existing structures set back 40 percent more or less than the average shall be discounted from the average setback calculation formula.

Building Bulk Limitation

The total floor area of the principal building on the lot shall not exceed 50% of the lot area or 2,500 square feet, whichever is greater. *[Attic and basement spaces are typically not included in total floor area].* The following exceptions to this standard are allowed:

- A. For buildings that already exceed the maximum floor area, an addition of up to 500 square feet may be permitted within any 15-year period.
- B. Floor area may be increased beyond the maximum when the established floor area of at least 50% of the principal buildings on the 5 developed lots or 300 feet on either side already exceeds the maximum floor area ratio. If this method is used, floor area shall not exceed that of the largest residential building within the specified distance (5 lots/300 feet).

Residential District Uses

Table R.1 lists all permitted and conditional uses in the residential districts.

- A. Uses marked as "P" are permitted in the districts where designated.
- B. Uses marked with a "C" are allowed as conditional uses in the districts where designated, in compliance with all applicable standards.
- C. Uses indicated as "P/C" may be permitted or conditional, depending on their size and scale, as specified.
- D. A "Y" in the "Standards" column means that specific standards must be complied with, whether the use is permitted or conditional. Standards are included in Subchapter __, Supplemental Regulations.

Residential Districts															
	SR-C1	SR-C2	SR-C3	SR-V1	SR-V2	TR-C1	TR-C2	TR-C3	TR-V1	TR-V2	TR-U1	TR-U2	TR-R	TR-P	Standards
Residential - Family Living															
Single-family detached dwellings	P	P	P	P	P	P	P	P	P	P	P	P	P	P	Y
Two-family dwelling – two- at			P	P	P			P	P	P	P	P		P	Y
Two-family dwelling - twin			P	P	P				P	P	P	P			Y
Three-family dwelling									P						Y
Single-family attached dwelling (3-8 dwelling units)										C	C	C			Y
Single-family attached dwelling (> 8 dwelling units)				C	C					C	C	C			Y
Multi-family dwelling (3-4 dwelling units)				P	P				P	P					Y
Multi-family dwelling (3-8 dwelling units)				C	P					P	C	C			Y
Multi-family dwelling (> 8 dwelling units)					C						C	C			Y
Multi-family building complex					C						C	C			Y
Accessory dwelling unit, attached or detached				status to be determined										P	Y
Residential - Group Living															
Adult family home meeting separation requirements	P	P	P	P	P	P	P	P	P	P	P	P	P	P	Y
Adult family home not meeting separation requirements	C	C	C	C	C	C	C	C	C	C	C	C	C	C	Y
Cohousing community															
Community living arrangement (up to 8 residents)	P	P	P	P	P	P	P	P	P	P	P	P	P	P	Y
Community living arrangement (> 8 residents)	C	C	C	C	C	C	C	C	C	C	C	C		C	Y
Co-operative housing															
Dormitory					C						C	C			Y
Lodging house, fraternity or sorority											C	C			Y
Elderly housing: assisted living, congregate care				C	C				C	C	C	C			Y

Residential Districts															
	SR-C1	SR-C2	SR-C3	SR-V1	SR-V2	TR-C1	TR-C2	TR-C3	TR-V1	TR-V2	TR-U1	TR-U2	TR-R	TR-P	Standards
Hostel											C	C			
Religious community	P	P	P	P	P	P	P	P	P	P	P	P		P	
Civic and Institutional															
Cemetery	C	C	C	C	C	C	C	C	C	C	C	C	C	C	
Day care center in school or religious inst.	P	P	P	P	P	P	P	P	P	P	P	P	C	P	
Day care center, nursery school	C	C	C	C	C	C	C	C	C	C	C	C		C	Y
Educational, office and recreational uses in former public school buildings	C	C	C	C	C	C	C	C	C	C	C	C		C	Y
Libraries	P	P	P	P	P	P	P	P	P	P	P	P		P	
Mission house in conjunction with religious institution	C	C	C	C	C	C	C	C	C	C	C	C		C	
Parks and playgrounds	P	P	P	P	P	P	P	P	P	P	P	P	P	P	
Place of worship	C	C	C	C	C	C	C	C	C	C	C	C	C	C	Y
Public safety facilities (fire, police stations, etc.)	P	P	P	P	P	P	P	P	P	P	P	P		P	
Schools, public and private	C	C	C	C	C	C	C	C	C	C	C	C		C	Y
Any structure with floor area exceeding 10,000 sq. ft.	C	C	C	C	C	C	C	C	C	C	C	C	C	C	Y
Other															
Bed and breakfast establishments	C	C	C	C	C	C	C	C	C	C	C	C		C	Y
Community garden	P	P	P	P	P	P	P	P	P	P	P	P		P	Y
Market garden	C	C	C	C	C	C	C	C	C	C	C	C		C	
Golf course, public or private	C	C	C	C	C	C	C	C	C	C	C	C		C	Y
Swimming and tennis clubs, private	C	C	C	C	C	C	C	C	C	C	C	C		C	Y
Limited retail use of landmark site or building											C	C			Y
Accessory Uses															
Day care home, children or adults	P	P	P	P	P	P	P	P	P	P	P	P		P	
Dwelling units or lodging rooms for persons employed on the premises as night watchmen, etc. (nonresidential uses only)	P	P	P	P	P	P	P	P	P	P	P	P	P	P	
Emergency electric generator	P	P	P	P	P	P	P	P	P	P	P	P	P	P	Y
Home occupation	P/ C	P/ C	P/ C	P/ C	P/ C	P/ C	P/ C	P/ C	P/ C	P/ C	P/ C	P/ C	P/ C	P/ C	Y
Garage, workshop, not exceeding maximum size	P	P	P	P	P	P	P	P	P	P	P	P	P	P	Y
Garage, workshop, exceeding maximum size	C	C	C	C	C	C	C	C	C	C	C	C		C	Y
Keeping of up to 4 chickens	P	P	P	P	P	P	P	P	P	P	P	P	P	P	Y
Lease of off-street parking space(s)	P	P	P	P	P	P	P	P	P	P	P	P	P	P	Y

Residential Districts															
	SR-C1	SR-C2	SR-C3	SR-V1	SR-V2	TR-C1	TR-C2	TR-C3	TR-V1	TR-V2	TR-U1	TR-U2	TR-R	TR-P	Standards
Management office for multi-family building or complex															
Parking lot accessory to a nonresidential use	C	C	C	C	C	C	C	C	C	C	C	C		C	Y
Parking lot exceeding ____% above minimum required parking	C	C	C	C	C	C	C	C	C	C	C	C		C	Y
Recreational facilities for multi-family building or complex					P					P	P	P			Y
Restaurant within multi-family building					C					C	C	C			Y
Limited retail within multi-family building					C					C	C	C			Y
Temporary Uses															
Dependency living arrangements	P	P	P	P	P	P	P	P	P	P	P	C	P	P	Y
Real estate sales office	P	P	P	P	P	P	P	P	P	P	P	P	P	P	Y
Temporary buildings for storage of materials and equipment	P	P	P	P	P	P	P	P	P	P	P	P	P	P	Y
Yard sales (max. 4 per year)	P	P	P	P	P	P	P	P	P	P	P	P	P	P	Y
Utility Uses															
Electric substations	C	C	C	C	C	C	C	C	C	C	C	C	C	C	
Gas regulator stations, mixing and gate stations	C	C	C	C	C	C	C	C	C	C	C	C	C	C	
Telecommunications towers and transmission equipment buildings	C	C	C	C	C	C	C	C	C	C	C	C	C	C	
Sewerage system lift stations	C	C	C	C	C	C	C	C	C	C	C	C	C	C	
Water pumping stations, water reservoirs	C	C	C	C	C	C	C	C	C	C	C	C	C	C	

Suburban Residential - Consistent Districts

Statement of Purpose

The SR-C Districts are established to stabilize and protect the essential characteristics of low- to moderate-density residential areas typically located in the outlying parts of the City, and to promote and encourage a suitable environment for family life. The districts are also intended to:

- A. Ensure that new buildings and additions to existing buildings are designed with sensitivity to their context in terms of building placement, facade width, height and proportions, garage and driveway placement, landscaping, and similar design features.
- B. Maintain and improve the viability of existing housing of all types, while providing for updating of older housing in a context-sensitive manner.
- C. Maintain or increase compatibility between residential and other allowed uses, and between different housing types, where permitted, by maintaining consistent building orientation and parking placement and screening.
- D. Facilitate the development or redevelopment goals of adopted neighborhood, corridor or special area plans.

Relationship to Comprehensive Plan

The SR-C districts are intended to implement the Objectives and Policies of the Comprehensive Plan, including, but not limited to, the Objectives and Policies for Established Neighborhoods (specifically Objectives 33, 36, 40, 41, 42 and 46).

SR-C1 (C5) District

[Residential neighborhoods within this district are characterized by single-family homes on generously-sized lots developed in compliance with the R-1 standards of the 1966 zoning code]

Permitted and Conditional Uses

See Table R.1 for a complete list of allowed uses within the residential districts.

Dimensional Standards, Permitted and Conditional Uses

Standards represent minimums unless otherwise noted. Dimensions are in feet unless otherwise noted.

SR-C1 District		
Building Type	Single-family detached	Nonresidential building
Lot Area (sq. ft.)	8,000	8,000
Lot Width	60	60
Front Yard Setback	30	30
Side Yard Setback	One-story: 6 Two-story: 7	30
Reversed Corner Side Yard Setback	15	
Rear Yard	30% lot depth but no less than 35	
Maximum height	2 stories/35	Equal to building height but at least 35
Maximum lot coverage	50%	50%
Maximum building coverage	n/a	50%
Usable open space (sq. ft.)	1,300	n/a

Building Forms

The following building forms are considered appropriate for the SR-C1 District. Other building forms may be acceptable provided that they match the list of allowed uses and meet the lot, height, frontage requirements and design standards of this Section and Section __.

- A. Single-family detached
- B. Civic/Institutional building

SR-C2 (C7) District

[Residential neighborhoods within this district are characterized by single-family homes on moderately sized lots developed in compliance with the R2 standards of the 1966 zoning code.]

Permitted and Conditional Uses

See Table R.1 for a complete list of allowed uses within the residential districts.

Dimensional Standards

Standards represent minimums unless otherwise noted. Dimensions are in feet unless otherwise noted.

SR-C2 District		
Building Type	Single-family detached	Nonresidential building
Lot Area (sq. ft.)	6,000	6,000
Lot Width	50	50
Front Yard Setback	30	30
Side Yard Setback	One-story: 6 Two-story: 7	30
Reversed Corner Side Yard Setback	15	
Rear Yard	30% lot depth but at least 35	
Maximum height	2 stories/35	Equal to building height but at least 35
Maximum lot coverage	50%	50%
Usable open space (sq. ft.)	1,000	n/a
Maximum building coverage	n/a	50%

Building Forms

The following building forms are considered appropriate for the SR-C2 District. Other building forms may be acceptable provided that they match the list of allowed uses and meet the lot, height, frontage requirements and design standards of this Section and Section __.

- A. Single-family detached
- B. Civic/Institutional building

SR-C3 (C11) District

[Residential neighborhoods within this district are typically characterized by two-family homes on moderately sized lots developed in compliance with the R3 standards of the 1966 zoning code.]

Permitted and Conditional Uses

See Table R.1 for a complete list of allowed uses within the residential districts.

Dimensional Standards, Permitted and Conditional Uses

Standards represent minimums unless otherwise noted. Dimensions are in feet unless otherwise noted.

Two-family two-flat: “stacked” units in 2-story building.

Two-family – twin: side-by-side units, aka “zero lot line.”

The lot area for the two-flat applies to the entire building; for the twin we assume (but don’t require) separate lots.

SR-C3 District				
Building Type	Single-family detached	Two-family - Two-at	Two-family - Twin	Nonresidential building
Lot Area (sq. ft.)	6,000	8,000	4,000/d.u.	6,000
Lot Width	50	50	25/d.u.	50
Front Yard Setback	25	25	25	25
Side Yard Setback	One-story: 5 Two-story: 6	Two-story: 6	One-story: 5 Two-story: 6 (one side only)	One-story: 5 Two-story: 6
Reversed Corner Side Yard Setback	15	15	15	25
Rear Yard	30% lot depth but at least 35	30% lot depth but at least 35	30% lot depth but at least 35	Equal to building height but at least 35
Maximum height	2 stories/35	2 stories/35	2 stories/35	n/a
Maximum lot coverage	60%	60%	60%	60%
Maximum building coverage	n/a	n/a	n/a	50%
Usable open space (sq. ft.)	750	750	750	n/a

Building Forms

The following building forms are considered appropriate for the SR-C3 District. Other building forms may be acceptable provided that they match the list of allowed uses and meet the lot, height, frontage requirements and design standards of this Section and Section __.

- A. Single-family detached
- B. Civic/Institutional building
- A. Single-family detached
- B. Two-family - two-flat
- C. Two-family - twin
- D. Civic/Institutional building

Suburban Residential - Varied Districts

Statement of Purpose

The SR-V Districts are established to stabilize and protect the essential characteristics of residential areas of varying densities and housing types, typically located in the outlying parts of the City, and to promote and encourage a suitable environment for family life. The districts are also intended to:

- A. Ensure that new buildings and additions to existing buildings are designed with sensitivity to their context in terms of building placement, facade width, height and proportions, garage and driveway placement, landscaping, and similar design features.
- B. Maintain and improve the viability of existing housing of all types, while encouraging the updating of older housing in a context-sensitive manner.
- C. Maintain or increase compatibility between residential and other allowed uses, and between different housing types, where permitted, by maintaining consistent building orientation and parking placement and screening.
- D. Facilitate the development or redevelopment goals of adopted neighborhood, corridor or special area plans.

Relationship to Comprehensive Plan

The SR-V districts are intended to implement the Objectives and Policies of the Comprehensive Plan, including, but not limited to, the Objectives and Policies for Established Neighborhoods (specifically Objectives 33, 36, 41, 42 and 46).

SR-V1 (V22)

[Residential neighborhoods within this district are typically characterized by two-family, single-family attached and small multi-family homes on small to moderately sized lots developed in compliance with the R3, R4 and R5 standards of the 1966 zoning code.]

Permitted and Conditional Uses

See Table R.1 for a complete list of allowed uses within the residential districts.

Dimensional Standards, Permitted and Conditional Uses

Standards represent minimums unless otherwise noted. Dimensions are in feet unless otherwise noted.

SR-V1 District: Permitted Uses				
Building Type	Single-family detached	Two-family - Two-at	Two-family - Twin	Three-four unit building
Lot Area (sq. ft.)	6,000	8,000	4,000/d.u.	4,000/d.u.
Lot Width	50	50	25/d.u.	60
Front Yard Setback	25	25	25	25
Side Yard Setback	One-story: 5 Two-story: 6	Two-story: 6	One-story: 5 Two-story: 6 (one side only)	6/15 total
Reversed Corner Side Yard Setback	15	12	12	12
Rear Yard	25% lot depth but at least 30	25% lot depth but at least 30	25% lot depth but at least 30	25% lot depth but at least 30
Maximum height	2 stories/35	2 stories/35	2 stories/35	3 stories/35
Maximum lot coverage	60%	60%	60%	60%
Usable open space (sq. ft.)	500	500	500	500

SR-V1 District: Conditional Uses			
Building Type	Single-family attached (8 units max.)	Multi-family (8 units max.)	Nonresidential building
Lot Area (sq. ft.)	2,000/d.u.	2,000/d.u.	6,000
Lot Width	20/d.u.	60	50
Front Yard Setback	25	25	25
Side Yard Setback	Two-story: 6	6 + 1 per unit > 2	One-story: 6 Two-story: 7 + 1 for every foot above 35 ft. bldg. ht.
Reversed Corner Side Yard Setback	12	12	25
Rear Yard	25% lot depth but at least 30	25% lot depth but at least 30	Equal to building height but at least 30
Maximum height	3 stories/35	3 stories/35	n/a
Maximum lot coverage	60%	60%	60%
Maximum building coverage	n/a	n/a	50%
Usable open space (sq. ft.)	500	500	n/a

- A. Density bonus for attached and multi-family buildings, enclosed parking: If underground or fully enclosed parking is provided, lot area may be reduced to 1,500 square feet per single-family attached or multi-family unit.
- B. Dispersion of dwellings: No attached or multi-family building containing over 4 dwelling units shall be constructed within 300 feet of any other attached or multi-family building located within the same block face.

Building Forms

The following building forms are considered appropriate for the SR-V1 District. Other building forms may be acceptable provided that they match the list of allowed uses and meet the lot, height, frontage requirements and design standards of this Section and Section __.

- A. Single-family detached
- B. Single-family detached
- C. Two-family - two-flat
- D. Two-family - twin
- E. Single-family attached building
- F. Small multi-family building
- G. Large multi-family building, stacked flats
- H. Civic/Institutional building

SR-V2 (V29?)

[Residential neighborhoods within this district are typically characterized by multi-family complexes of multiple buildings, developed in compliance with the R4 and R5 standards of the 1966 zoning code. Some neighborhoods also include lower-density housing types]

Permitted and Conditional Uses

See Table R.1 for a complete list of allowed uses within the residential districts.

Dimensional Standards, Permitted and Conditional Uses

Standards represent minimums unless otherwise noted. Dimensions are in feet unless otherwise noted.

SR-V2 District: Permitted Uses					
Building Type	Single-family detached	Two-family - Two- at	Two-family - Twin	Single-family attached (8 units max.)	Multi-family (8 units max.)
Lot Area (sq. ft.)	6,000	8,000	4,000/d.u.	2,000/d.u.	2,000/d.u.
Lot Width	50	50	25/d.u.	20/d.u.	60
Front Yard Setback	25	25	25	25	25
Side Yard Setback	One-story: 5 Two-story: 6	Two-story: 6	One-story: 5 Two-story: 6 (one side only)	10 (end units)	6 + 1 per unit >2
Reversed Corner Side Yard Setback	15	12	12	12	12
Rear Yard	25% lot depth but at least 30	25% lot depth but at least 30	25% lot depth but at least 30	25% lot depth but at least 30	25% lot depth but at least 30
Maximum height	2 stories/35	2 stories/35	2 stories/35	3 stories/35	3 stories/35
Maximum lot coverage	60%	60%	60%	60%	60%
Usable open space (sq. ft.)	500	500	500	500	500

SR-V2 District: Conditional Uses			
Building Type	Single-family attached	Multi-family	Nonresidential building
Lot Area (sq. ft.)	2,000/d.u.	2,000/d.u.	6,000
Lot Width	20/d.u.	60	50
Front Yard Setback	25	25	25
Side Yard Setback	Two-story: 6	6 + 1 per unit > 2	One-story: 6 Two-story: 7 + 1 for every foot above 35 ft. bldg. ht.
Reversed Corner Side Yard Setback	12	12	25
Rear Yard	25% lot depth but at least 30	25% lot depth but at least 30	Equal to building height but at least 30
Maximum height	3 stories/35	3 stories/35	n/a
Maximum lot coverage	60%	60%	60%
Maximum building coverage	n/a	n/a	50%
Usable open space (sq. ft.)	500	500	n/a

- A. Density bonus for attached and multi-family buildings, enclosed parking: If underground or fully enclosed parking is provided, maximum building height may be increased to 4 stories/50', and lot area may be reduced to 1,500 square feet per single-family attached or multi-family unit.

Building Forms

The following building forms are considered appropriate for the SR-V2 District. Other building forms may be acceptable provided that they match the list of allowed uses and meet the lot, height, frontage requirements and design standards of this Section and Section __.

- A. Single-family detached
- B. Single-family detached
- C. Two-family - two-flat
- D. Two-family - twin
- E. Single-family attached building
- F. Small multi-family building
- G. Large multi-family building, stacked flats
- H. Civic/Institutional building

Traditional Residential - Consistent Districts

Statement of Purpose

The TR-C Districts are established to stabilize and protect the essential characteristics of mature residential areas typically located on the Isthmus, near East and near West portions of the City, and to promote and encourage a suitable environment for family life while accommodating a full range of life-cycle housing. The districts are also intended to:

- A. Promote the preservation, development and redevelopment of traditional residential neighborhoods in a manner consistent with their distinct form and residential character.
- B. Ensure that new buildings and additions to existing buildings are designed with sensitivity to their context in terms of building placement, facade width, height and proportions, garage and driveway placement, landscaping, and similar design features.
- C. Maintain and improve the viability of existing housing of all types, while providing for updating of older housing in a context-sensitive manner.
- D. Maintain or increase compatibility between residential and other allowed uses, and between different housing types, where permitted, by maintaining consistent building orientation and parking placement and screening.
- E. Facilitate the development or redevelopment goals of adopted neighborhood, corridor or special area plans.

Relationship to Comprehensive Plan

The TR-C districts are intended to implement the Objectives and Policies of the Comprehensive Plan, including, but not limited to, the Objectives and Policies for Established Neighborhoods (specifically Objectives 40, 41 and 42) and the Objectives and Policies for Future Neighborhoods (specifically Objectives 27-33).

TR-C1 (C7?) District

[Residential neighborhoods within this district are characterized by modestly-sized, primarily single-family buildings on relatively narrow lots that were developed prior to the 1966 zoning code. Most garages are detached and placed in rear or side yards.]

Permitted and Conditional Uses

See Table R.1 for a complete list of allowed uses within the residential districts.

Dimensional Standards, Permitted and Conditional Uses

Standards represent minimums unless otherwise noted. Dimensions are in feet unless otherwise noted.

TR-C1 District		
Building Type	Single-family detached	Nonresidential building
Lot Area (sq. ft.)	6,000	6,000
Lot Width	50	50
Front Yard Setback	20	20
Maximum Front Yard Setback	no more than 20% greater than block average, up to 30 max.	
Side Yard Setback	One-story: 6 Two-story: 7	20
Reversed Corner Side Yard Setback	15	15
Rear Yard	30% lot depth but at least 35	Equal to building height but at least 35
Maximum height	2 stories/35	n/a
Maximum lot coverage	50%	50%
Usable open space (sq. ft.)	1,000	n/a
Maximum building coverage	n/a	50%

Building Forms

The following building forms are considered appropriate for the TR-C1 District. Other building forms may be acceptable provided that they match the list of allowed uses and meet the lot, height, frontage requirements and design standards of this Section and Section ____.

- A. Single-family detached building
- B. Civic/Institutional building

TR-C2 (C9?)

[Residential neighborhoods within this district are characterized by modestly-sized, primarily single-family buildings on relatively small and narrow lots that were developed prior to the 1966 zoning code. Most garages are detached and placed in rear or side yards. Because of lot sizes, building modifications can be challenging.]

Permitted and Conditional Uses

See Table R.1 for a complete list of allowed uses within the residential districts.

Dimensional Standards, Permitted and Conditional Uses

Standards represent minimums unless otherwise noted. Dimensions are in feet unless otherwise noted.

TR-C2 District		
Building Type	Single-family detached	Nonresidential building
Lot Area (sq. ft.)	4,800	4,800
Lot Width	40	40
Front Yard Setback	20	20
Maximum Front Yard Setback	no more than 20% greater than block average, up to 30 max.	
Side Yard Setback	One-story: 5 Two-story: 6 Lot width <40: 10% lot width	20
Reversed Corner Side Yard Setback	12	20
Rear Yard	30% lot depth but at least 30	Equal to building height but at least 30
Maximum height	2 stories/35	n/a
Maximum lot coverage	65%	65%
Usable open space (sq. ft.)	750	n/a
Maximum building coverage	n/a	50%

Building Forms

The following building forms are considered appropriate for the TR-C2 District. Other building forms may be acceptable provided that they match the list of allowed uses and meet the lot, height, frontage requirements and design standards of this Section and Section ___.

- A. Single-family detached building
- B. Civic/Institutional building

TR-C3 (C18?) District

[Residential neighborhoods within this district are characterized by modestly-sized, primarily single-family and two-family buildings on relatively small and narrow lots that were developed prior to the 1966 zoning code. Most garages are detached and placed in rear or side yards. Because of lot sizes, building modifications can be challenging. The TR-C3 district is established to allow a mixture of single- and two-family dwellings while maintaining the occupancy limits of the current R4A district.]

Permitted and Conditional Uses

See Table R.1 for a complete list of allowed uses within the residential districts.

Dimensional Standards, Permitted and Conditional Uses

Standards represent minimums unless otherwise noted. Dimensions are in feet unless otherwise noted.

TR-C3 District			
Building Type	Single-family detached	Two-family -Two- at	Nonresidential building
Lot Area (sq. ft.)	4,800	4,800	4,800
Lot Width	40	40	40
Front Yard Setback	20	20	20
Maximum Front Yard Setback	no more than 20% greater than block average, up to 30 max.	no more than 20% greater than block average, up to 30 max.	n/a
Side Yard Setback	One-story: 5 Two-story: 6 Lot width < 40: 10% lot width	Two-story: 6 Lot width < 40: 10% lot width	One-story: 5 Two-story: 6 + 1 for every foot above 35 in ht.
Reversed Corner Side Yard Setback	12	12	20
Rear Yard	30% lot depth but at least 30	30% lot depth but at least 30	Equal to building height but at least 30
Maximum height	2 stories/35	2 stories/35	n/a
Maximum lot coverage	65%	65%	65%
Maximum building coverage	n/a	n/a	50%
Usable open space (sq. ft.)	750	750	n/a

Building Forms

The following building forms are considered appropriate for the TR-C3 District. Other building forms may be acceptable provided that they match the list of allowed uses and meet the lot, height, frontage requirements and design standards of this Section and Section ____.

- A. Single-family detached building
- B. Two-flat building
- C. Civic/Institutional building

Traditional Residential - Varied Districts

Statement of Purpose

The TR-V Districts are established to stabilize and protect the essential characteristics of mature residential areas typically located on the Isthmus, near Downtown and near the University of Wisconsin campus, and to accommodate a full range of life-cycle housing while encouraging a suitable environment for family life. The districts are also intended to:

- A. Promote the preservation, development and redevelopment of traditional residential neighborhoods in a manner consistent with their distinct form and residential character.
- B. Ensure that new buildings and additions to existing buildings are designed with sensitivity to their context in terms of building placement, facade width, height and proportions, garage and driveway placement, landscaping, and similar design features.
- C. Maintain and improve the viability of existing housing of all types, while providing for updating of older housing in a context-sensitive manner.
- D. Maintain or increase compatibility between residential and other allowed uses, and between different housing types, where permitted, by maintaining consistent building orientation and parking placement and screening.
- E. Facilitate the development or redevelopment goals of adopted neighborhood, corridor or special area plans.

Relationship to Comprehensive Plan

The TR-V districts are intended to implement the Objectives and Policies of the Comprehensive Plan, including, but not limited to, the Objectives and Policies for Established Neighborhoods (specifically Objectives 40, 41 and 42) and the Objectives and Policies for Future Neighborhoods (specifically Objectives 27-33).

Residential Design Guidelines

All new development and major additions or remodels [threshold to be determined] within the TR-V Districts shall comply with the following design guidelines to the extent feasible, and with the Building Form standards of Section __:

- A. Orientation. New buildings shall be oriented with the shorter dimension parallel to the street, in a manner consistent with existing traditional residential buildings on the block.
- B. Proportions. New buildings and major additions shall be designed with scale and proportions consistent with existing traditional residential buildings on the block.

TR-V1 (V10?) District

[Residential neighborhoods within this district are typically characterized by a mixture of single-family, two-family and three-family homes on small to moderately sized lots, developed prior to the 1966 zoning code and frequently zoned R3 or R4 under that code.]

Permitted and Conditional Uses

See Table R.1 for a complete list of allowed uses within the residential districts.

Dimensional Standards, Permitted and Conditional Uses

Standards represent minimums unless otherwise noted. Dimensions are in feet unless otherwise noted.

TR-V1 District: Permitted Uses				
Building Type	Single-family detached	Two-family - Two-at	Two-family - Twin	Three- at building
Lot Area (sq. ft.)	6,000	8,000	4,000/d.u.	8,000
Lot Width	50	50	25/d.u.	50
Front Yard Setback	20	20	20	20
Maximum Front Yard Setback	no more than 20% greater than block average, up to 30 max.	no more than 20% greater than block average, up to 30 max.	no more than 20% greater than block average, up to 30 max.	no more than 20% greater than block average, up to 30 max.
Side Yard Setback	One-story: 5 Two-story: 6	Two-story: 6	One-story: 5 Two-story: 6 (one side only)	One-story: 5 Two-story: 6
Reversed Corner Side Yard Setback	12	12	12	12
Rear Yard	25% lot depth but at least 30	25% lot depth but at least 30	25% lot depth but at least 30	25% lot depth but at least 30
Maximum height	2 stories/35	2 stories/35	2 stories/35	3 stories/35
Maximum lot coverage	65%	65%	65%	65%
Usable open space (sq. ft.)	500	500	500	500

- A. Dispersion of dwellings: No three-flat building shall be constructed within 300 feet of any other three-flat, attached or multi-family building located within the same block. *[Should a 4-unit building be allowed with same requirement?]*

TR-V2 (V22?) District

[Residential neighborhoods within this district are typically characterized by small multi-family buildings, including multi-family conversions of single-family buildings, interspersed with single-, two- and three-family buildings. These neighborhoods were developed prior to the 1966 zoning code and frequently zoned R4 under that code.]

Permitted and Conditional Uses

See Table R.1 for a complete list of allowed uses within the residential districts.

Dimensional Standards, Permitted and Conditional Uses

Standards represent minimums unless otherwise noted. Dimensions are in feet unless otherwise noted.

TR-V2 District: Permitted Uses				
Building Type	Single-family detached	Two-family - Two-at	Two-family - Twin	Three-four unit building
Lot Area (sq. ft.)	4,800	4,800	4,800/d.u.	3,000/d.u.
Lot Width	40	40	20/d.u.	60
Front Yard Setback	20	20	20	20
Maximum Front Yard Setback	no more than 20% greater than block average, up to 30 max.	no more than 20% greater than block average, up to 30 max.	no more than 20% greater than block average, up to 30 max.	no more than 20% greater than block average, up to 30 max.
Side Yard Setback	One-story: 5 Two-story: 6	Two-story: 6	One-story: 5 Two-story: 6 (one side only)	6/15 total
Reversed Corner Side Yard Setback	15	12	12	12
Rear Yard	25% lot depth but at least 30	25% lot depth but at least 30	25% lot depth but at least 30	25% lot depth but at least 30
Maximum height	2 stories/35	2 stories/35	2 stories/35	3 stories/35
Maximum lot coverage	65%	65%	65%	65%
Usable open space (sq. ft.)	500	500	500	500

TR-V2 District: Conditional Uses			
Building Type	Single-family attached (8 units max.)	Multi-family (8 units max.)	Nonresidential building
Lot Area (sq. ft.)	2,000/d.u.	2,000/d.u.	6,000
Lot Width	20/d.u.	60	50
Front Yard Setback	25	25	25
Maximum Front Yard Setback	no more than 20% greater than block average, up to 30 max.	no more than 20% greater than block average, up to 30 max.	no more than 20% greater than block average, up to 30 max.

Side Yard Setback	Two-story: 6	6 + 1 per unit > 2	One-story: 6 Two-story: 7 + 1 per foot above 35 in bldg. ht.
Reversed Corner Side Yard Setback	12	12	20
Rear Yard	25% lot depth but at least 30	25% lot depth but at least 30	Equal to building height but at least 30
Maximum height	3 stories/35	3 stories/35	n/a
Maximum lot coverage	65%	65%	65%
Maximum building coverage	n/a	n/a	50%
Usable open space (sq. ft.)	500	500	n/a

- A. Density bonus for attached and multi-family buildings, enclosed parking: If underground or fully enclosed parking is provided, lot area may be reduced to 1,500 square feet per single-family attached or multi-family unit.

Building Forms

The following building forms are considered appropriate for the TR-V2 District. Other building forms may be acceptable provided that they match the list of allowed uses and meet the lot, height, frontage requirements and design standards of this Section and Section ____.

- A. Single-family detached
- B. Single-family detached
- C. Two-family - two-flat
- D. Two-family - twin
- E. Single-family attached building
- F. Small multi-family building
- G. Large multi-family building, stacked flats
- H. Civic/Institutional building

Traditional Residential - Urban Districts

Statement of Purpose

The TR-U Districts are established to stabilize and protect the essential characteristics of high-density residential area typically located near Downtown and near the University of Wisconsin campus, and to accommodate a full range of life-cycle housing. The districts are also intended to:

- A. Ensure that new buildings and additions to existing buildings are designed with sensitivity to their context in terms of building placement, facade width, height and proportions, garage and driveway placement, landscaping, and similar design features.
- B. Promote the preservation of historic buildings and districts within or close to concentrations of high-density housing.
- C. Maintain and improve the viability of existing housing of all types, while providing for updating of older housing in a context-sensitive manner.
- D. Encourage restoration of single-family dwellings previously converted to multi-family units back to single- or two-family dwellings.
- E. Maintain or increase compatibility between residential and other allowed uses, and between different housing types, where permitted, by maintaining consistent building orientation and parking placement and screening.
- F. Facilitate the development or redevelopment goals of adopted neighborhood, corridor or special area plans.

Relationship to Comprehensive Plan

The TR-U districts are intended to implement the Objectives and Policies of the Comprehensive Plan, including, but not limited to, the Objectives and Policies for Established Neighborhoods (specifically Objectives 34, 36, 40, 41, 42 and 46).

Residential Design Guidelines

All new development and major additions or remodels [threshold to be determined] within the TR-U Districts shall comply with the following design guidelines to the extent feasible, and with the Building Form standards of Section __:

- A. Orientation. New buildings shall be oriented with the shorter dimension parallel to the street, in a manner consistent with existing traditional residential buildings on the block.
- B. Proportions. New buildings and major additions shall be designed with scale and proportions consistent with existing traditional residential buildings on the block.

TR-U1 (U40?) District

[Residential neighborhoods within this district are typically characterized by large and small low-rise multi-family buildings, including multi-family conversions of single-family buildings, interspersed with single-, two- and three-family buildings. These neighborhoods were developed prior to the 1966 zoning code and frequently zoned R5 under that code.]

Permitted and Conditional Uses

See Table R.1 for a complete list of allowed uses within the residential districts.

Dimensional Standards, Permitted and Conditional Uses

Standards represent minimums unless otherwise noted. Dimensions are in feet unless otherwise noted.

TR-U1 District: Permitted Uses					
Building Type	Single-family detached	Two-family - Two-at	Two-family - Twin	Single-family attached (max. 8 units)	Multi-family (max. 8 units)
Lot Area (sq. ft.)	6,000	8,000	4,000/d.u.	1,000/d.u.	1,000/d.u. + 300 per bedroom >2
Lot Width	50	50	25/d.u.	20/d.u.	50
Front Yard Setback	15	15	15	15	15
Maximum Front Yard Setback	no more than 20% greater than block average, up to 30 max.	no more than 20% greater than block average, up to 30 max.	no more than 20% greater than block average, up to 30 max.	no more than 20% greater than block average, up to 30 max.	no more than 20% greater than block average, up to 30 max.
Side Yard Setback	One-story: 5 Two-story: 6	Two-story: 6	One-story: 5 Two-story: 6 (one side only)	8 (end units)	6 + 1 per unit >2
Reversed Corner Side Yard Setback	15	12	12	12	12
Rear Yard	25% lot depth but at least 30	25% lot depth but at least 30	25% lot depth but at least 30	25% lot depth but at least 30	25% lot depth but at least 30
Maximum height	2 stories/35	2 stories/35	2 stories/35	3 stories/35	3 stories/35
Maximum lot coverage	65%	65%	65%	70%	70%
Usable open space (sq. ft.)	320	320/d.u.	320/d.u.	320/d.u.	320/d.u.

TR-U1 District: Conditional Uses			
Building Type	Single-family attached	Multi-family	Nonresidential building
Lot Area (sq. ft.)	1,000/d.u.	1,000/d.u. + 300 per bedroom >2	6,000
Lot Width	20/d.u.	50	50
Front Yard Setback	15	15	15
Maximum Front Yard Setback	no more than 20% greater than block average, up to 30 max.	no more than 20% greater than block average, up to 30 max.	n/a
Side Yard Setback	8 (end units)	6 + 1 per unit >2	One-story: 5 Two-story: 6 + 1 per foot above 35 in bldg. ht.
Reversed Corner Side Yard Setback	12	12	15
Rear Yard	25% lot depth but at least 30	25% lot depth but at least 30	Equal to building height but at least 30
Maximum height	3 stories/35	3 stories/35	n/a
Maximum lot coverage	70%	70%	70%
Maximum building coverage	n/a	n/a	50%
Usable open space (sq. ft.)	320/d.u.	320/d.u.	n/a

- A. Density bonus for enclosed parking, attached and multi-family buildings. If underground or fully enclosed parking is provided, maximum building height may be increased to 4 stories/50 feet.

Building Forms

The following building forms are considered appropriate for the TR-V2 District. Other building forms may be acceptable provided that they match the list of allowed uses and meet the lot, height, frontage requirements and design standards of this Section and Section ___.

- A. Single-family detached
- B. Single-family detached
- C. Two-family - two-flat
- D. Two-family - twin
- E. Single-family attached building
- F. Small multi-family building
- G. Large multi-family building, stacked flats
- H. Civic/Institutional building

TR-U2 (U70?) District

[Residential neighborhoods within this district are typically characterized by large multi-story multi-family buildings, interspersed with multi-family conversions of single-family buildings, and single, two- and three-family buildings. These neighborhoods were developed prior to the 1966 zoning code and frequently zoned R5 and R6 under that code.

Note that this district has no fixed height limit for multi-family buildings (as yet) because height will be governed by various downtown height limits. (Current R6 has no height limit but it does have a floor area ratio maximum of 2.0.) Question: should a height limit be established for locations outside of the downtown height zones?]

Based on Advisory Committee comments, this draft allows a broader range of multi-family uses by right in the TR-V and U districts. To distinguish between TR-U1 and U2, we are suggesting some increases in density for these housing types in TR-U2, similar to the current R6.

Permitted and Conditional Uses

See Table R.1 for a complete list of allowed uses within the residential districts.

Dimensional Standards, Permitted and Conditional Uses

Standards represent minimums unless otherwise noted. Dimensions are in feet unless otherwise noted.

TR-U2 District: Permitted Uses					
Building Type	Single-family detached	Two-family - Two-at	Two-family - Twin	Single-family attached (max. 8 units)	Multi-family (max. 8 units)
Lot Area (sq. ft.)	6,000	8,000	4,000/d.u.	800/d.u.	600/d.u. + 300 per bedroom >2
Lot Width	50	50	25/d.u.	20/d.u.	50
Front Yard Setback	15	15	15	15	15
Maximum Front Yard Setback	no more than 20% greater than block average, up to 30 max.	no more than 20% greater than block average, up to 30 max.	no more than 20% greater than block average, up to 30 max.	no more than 20% greater than block average, up to 30 max.	no more than 20% greater than block average, up to 30 max.
Side Yard Setback	One-story: 5 Two-story: 6	Two-story: 6	One-story: 5 Two-story: 6 (one side only)	8 (end units)	6 + 1 per unit >2
Reversed Corner Side Yard Setback	15	12	12	12	12
Rear Yard	25% lot depth but at least 30	25% lot depth but at least 30	25% lot depth but at least 30	25% lot depth but at least 30	25% lot depth but at least 30
Maximum height	2 stories/35	2 stories/35	2 stories/35	3 stories/35	4 stories/50
Maximum lot coverage	65%	65%	65%	75%	75%
Usable open space (sq. ft.)	320	320/d.u.	320/d.u.	140/d.u.	140/d.u.

TR-U2 District: Conditional Uses			
Building Type	Single-family attached	Multi-family	Nonresidential building
Lot Area (sq. ft.)	800/d.u.	600/d.u. + 300 per bedroom >2	6,000
Lot Width	20/d.u.	50	50
Front Yard Setback	15	15	15
Maximum Front Yard Setback	no more than 20% greater than block average, up to 30 max.	no more than 20% greater than block average, up to 30 max.	n/a
Side Yard Setback	8 (end units)	6 + 1 per unit >2	One-story: 5 Two-story: 6 + 1 per foot above 35 in bldg. ht.
Reversed Corner Side Yard Setback	12	12	15
Rear Yard	25% lot depth but at least 30	25% lot depth but at least 30	Equal to building height but at least 30
Maximum height	3 stories/35	To be determined	n/a
Maximum lot coverage	75%	80%	75%
Maximum building coverage	n/a	n/a	50%
Usable open space (sq. ft.)	140/d.u.	140/d.u.	n/a

Building Forms

The following building forms are considered appropriate for the TR-V2 District. Other building forms may be acceptable provided that they match the list of allowed uses and meet the lot, height, frontage requirements and design standards of this Section and Section ___.

- A. Single-family detached
- B. Single-family detached
- C. Two-family - two-flat
- D. Two-family - twin
- E. Single-family attached building
- F. Small multi-family building
- G. Large multi-family building, stacked flats
- H. Civic/Institutional building

Traditional Residential - Rustic (TR-R) District

[This district is intended to essentially mirror the R1-R Rustic Residence District, with a few minor updates.]

Statement of Purpose

The TR-R District is established to stabilize and protect the natural beauty, historic character and park-like setting of certain heavily wooded low-density residential neighborhoods. The district is also intended to promote the preservation of the neighborhood's historic buildings, tree cover and landscape plan.

Permitted and Conditional Uses

See Table R.1 for a complete list of allowed uses within the residential districts.

Dimensional Standards, Permitted and Conditional Uses

Standards represent minimums unless otherwise noted. Dimensions are in feet unless otherwise noted.

Name changed from "Estate" back to "Rustic" per resident wishes.

Note: there is currently no minimum lot width in the R-1R District; a 65' width would be a new requirement that is consistent with the existing development pattern.

Maximum height in R1-R is currently "3 stories" with no limit in feet. We are suggesting 40'.

"Lot coverage" in R1-R is currently defined to mean total floor area of new construction. The proposed new definition of lot coverage for all districts is building and impervious surface coverage

TR-R District: Permitted and Conditional Uses		
Building Type	Single-family detached	Nonresidential building
Lot Area (sq. ft.)	0.6 acres (26,136 sq. ft.)	0.6 acres (26,136 sq. ft.)
Lot Width	65	65
Front Yard Setback	50	50
Side Yard Setback	30	30
Reversed Corner Side Yard Setback	30	30
Rear Yard	40	40
Maximum height	3 stories/40	n/a
Maximum lot coverage	15%	15%
Maximum area accessory building (see below)	800 sq. ft.	as determined by CUP

- A. Detached Garage Replacement. New detached garages are not permitted. Detached garages existing as of January 1, 1989 may be replaced with a structure no larger than 800 square feet or the size of the principal building, whichever is less.

Traditional Residential - Planned (TR-P) District

[This district is intended to incorporate the standards of the R2-S, T, Y and Z Districts in a single mixed-density residential district.]

Statement of Purpose

The TR-P District is established to encourage the development of planned neighborhoods in close-in or outlying parts of the City that incorporate the characteristics of existing traditional neighborhoods. Features include a variety of lot sizes, detached or rear-loaded garages, traditional architectural features such as porches, and an interconnected street system.

Permitted and Conditional Uses

See Table R.1 for a complete list of allowed uses within the residential districts.

Dimensional Standards, Permitted and Conditional Uses

Standards represent minimums unless otherwise noted. Dimensions are in feet unless otherwise noted.

The R2 S-Z districts currently allow only single-family detached dwellings and secondary (accessory) dwellings, attached and detached. Per comments received, this draft adds two-family housing types.

The R2 S-Z district lot sizes and widths range from 3,500 to 5,000 and 37' to 44 feet. The R2Z (smallest) lots are intended to not exceed 25% of the total lots. This draft recommends a common 4,000 square foot lot size for single-family detached.

TR-P District: Permitted and Conditional Uses					
Building Type	Single-family detached	Two-family - Two-at	Two-family - Twin	Accessory dwelling unit	Nonresidential building
Lot Area (sq. ft.)	4,000	4,000	2,500/d.u.	5,000 (for principal building)	5,000
Lot Width	40	40	22/d.u.	60	60
Front Yard Setback	15	15	15	n/a	15
Maximum Front Yard Setback	no more than 20% greater than block average, up to 30 max.	no more than 20% greater than block average, up to 30 max.	no more than 20% greater than block average, up to 30 max.	no more than 20% greater than block average, up to 30 max.	no more than 20% greater than block average, up to 30 max.
Side Yard Setback	5	5	5	5	5
Reversed Corner Side Yard Setback	8 (10 for garage)	8 (10 for garage)	8 (10 for garage)	5	15
Rear Yard	20, or 2 for attached garage adjacent to alley	20, or 2 for attached garage adjacent to alley	20, or 2 for attached garage adjacent to alley	5, 3 if adjacent to alley	Equal to building height bot at least 20
Maximum height	2 stories/35	2 stories/35	2 stories/35	3 stories/35	3 stories/35
Maximum lot coverage	60%	60%	60%	n/a	60%
Usable open space (sq. ft.)	500	500/d.u.	500	800 (for principal building)	n/a

Related Definitions

[These definitions will add to or replace current ones in that section of the Code]

Community garden: An area of land managed and maintained by a group of individuals to grow and harvest food crops and/or non-food, ornamental crops, such as flowers, for personal or group use, consumption or donation. Community gardens may be divided into separate plots for cultivation by one or more individuals or may be farmed collectively by members of the group and may include common areas maintained and used by group members.

Market garden: An area of land managed and maintained by an individual or group of individuals to grow and harvest food crops and/or non-food, ornamental crops, such as flowers, to be sold for profit.

Front façade: The wall of building closest to the street that separates interior living spaces from exterior. An open porch without living space above it shall not be considered a front façade. For buildings on corner or through lots, the front façade is usually that façade that fronts the street of higher classification.

Lot coverage: The total area of all buildings, measured at grade, all accessory structures including pools, patios, etc., and all paved areas as a percentage of the total area of the lot, with the following exceptions: sidewalks or paved paths no wider than 5 feet, pervious pavement, and green roofs.

Natural Grade: The grade of a site before it is modified by moving earth, adding or removing fill, or installing a berm, retaining wall or other earthwork feature. Natural grade is determined by reference to a survey, or other information as determined by the zoning administrator.

Pervious pavement: Pavement that is designed and maintained to allow precipitation to infiltrate into the ground, in order to reduce the volume of stormwater runoff. Pervious pavement materials include pervious interlocking concrete paving blocks, concrete grid pavers, perforated brick pavers, and similar materials determined by the City Engineer to qualify.

Usable open space: That portion of a zoning lot outside of a required front or corner side yard that is available to all occupants for outdoor use. Usable open space shall not include areas occupied by buildings, driveways, drive aisles, on-street parking, or paving, with the exception of greenhouses and swimming pool domes approved as conditional uses, sidewalks or paved paths no wider than 5 feet, and pervious pavement. Usable open space may include balconies and roof decks where specified in this ordinance.

Yards: Open space on a zoning lot between the principal building and the adjoining lot lines. The term "required yard" refers to that portion of the lot that is required to remain open, except for allowed encroachments. "Required yard" is equivalent to the term "setback."

The definition of "yard" is the more commonly accepted one - as distinct from "required yard."

