

TYPE 'A' CONCRETE
CURB & GUTTER

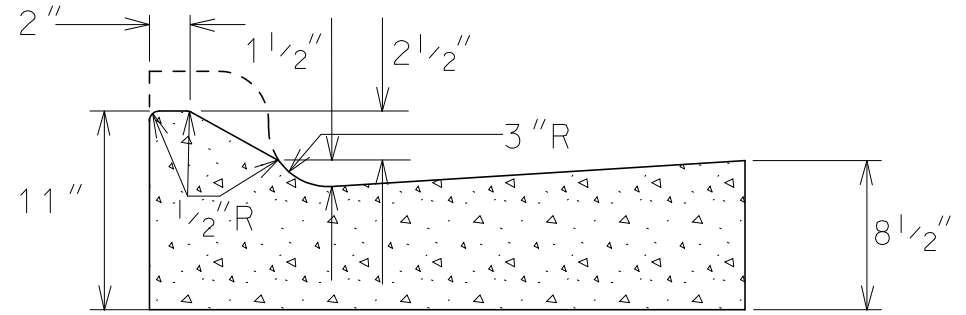

TYPE 'A' MOUNTABLE CONCRETE
CURB & GUTTER
(PAY AS TYPE 'A' CURB AND GUTTER)

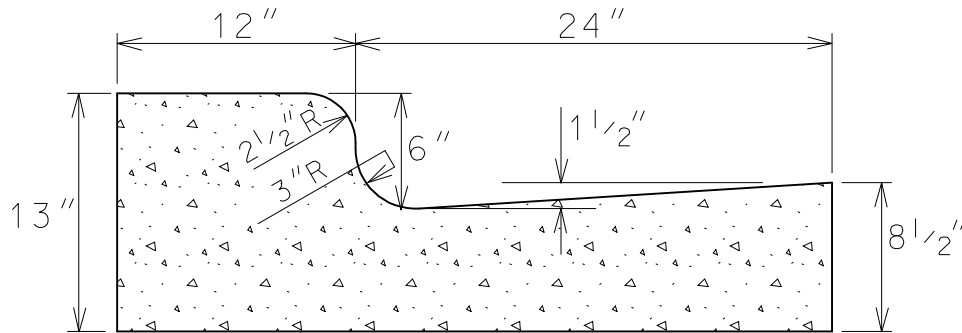

TYPE 'B' CONCRETE
CURB & GUTTER

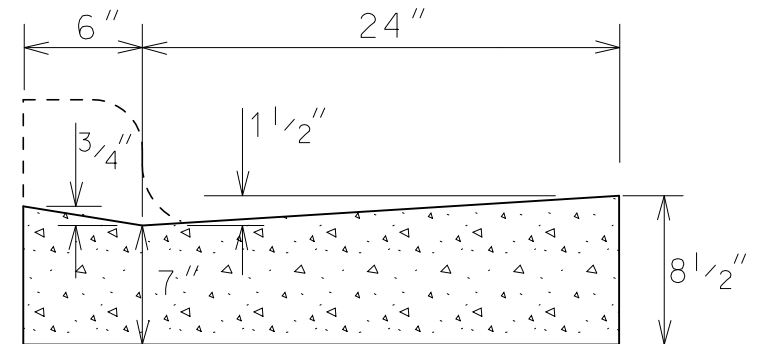

DRIVEWAY SECTION TYPE 'A'
CONCRETE CURB & GUTTER
(PAY AS TYPE 'A' CURB AND GUTTER)

GENERAL NOTES:

LATERAL CONTRACTION JOINTS SHALL BE PLACED AT INTERVALS OF NOT MORE THAN 15' NOR LESS THAN 6' IN LENGTH. THE JOINTS SHALL BE A MINIMUM OF 3" IN DEPTH

EXPANSION JOINTS SHALL BE PLACED TRANSVERSLY AT RADIUS POINTS ON CURVES OF RADIUS 200' OR LESS, AND AT ANGLE POINTS, OR AS DIRECTED BY THE ENGINEER. THE EXPANSION JOINT SHALL BE A ONE PIECE ASPHALTIC MATERIAL HAVING THE SAME DIMENSIONS AS CURB & GUTTER AT THAT STATION AND BE 1/2" THICK.

IN ALL CASES, CONCRETE CURB & GUTTER SHALL BE PLACED ON THOROUGHLY COMPACTED CRUSHED STONE

2004

CITY OF MADISON
ENGINEERING DIVISION

MADISON STANDARD
CONCRETE CURB & GUTTER

STANDARD DETAIL DRAWING 3.06