

Madison's Utility Box Art Program

Utility Boxes

See schematic on reverse



Before



After

Original artwork and photo: Craig Wilson



Original artwork: Craig Wilson, photo of utility box: Jane Lee

Call for Entries

DEADLINE: AUGUST 31, 2017

The City of Madison is seeking visual artists to submit their artwork for possible placement on City-owned utility boxes. **Madison's Utility Box Art Program** will give Madison artists the opportunity to transform ordinary objects of urban infrastructure into something fun and unique, enhancing our public spaces.

Chosen artists will be expected to submit their images in a high resolution digital format upon request (not at time of application). Artists will be paid a \$400 licensing fee for rights to use their image on the utility box and in promotional materials. Artist's name and title of artwork will appear on the utility box.

This program is intended to highlight, encourage and promote Madison artists by giving them the opportunity to present their artwork publicly.

Community Art Box Program. In partnership with Madison Public Library's Bubbler program, a limited number of boxes in locations near libraries or other community centers will showcase the work of community artists, students, or community groups. Those chosen for this opportunity will need to provide the City with permission to use the image and will not be compensated. For more information check the Bubbler web site (madisonbubbler.org/boxes)

Selection Process

A selection committee of the Madison Arts Commission will review applications and will invite up to 30 artists to provide high resolution images (for enlargement to at least 6' x 4'). Selected artists will each receive a licensing fee of \$400 per image upon completion of an art release / waiver. Location, layout, and length of artwork installation will be determined by the City of Madison. *MAC has the right to decline all submissions and retract this call for entries for any reason at any time.*

How to Submit

All application materials must be received via Dropbox (see info on reverse) by 11:59 on **August 31, 2017**. Applicants with technical limitations, and for general questions, please contact the Arts Program Administrator (madisonarts@cityofmadison.com).

Madison Arts Commission (MAC's) mission is to foster arts appreciation by initiating partnerships, developing new audiences, and sponsoring diverse artistic activities by emerging and established artists and arts organizations while preserving Madison's rich artistic tradition.

Application Submission

Submit the following materials (*NOTE: Use label style shown in italics, replace **JDoe** with your first initial and last name.*)

- A. **Cover letter:** including Artist's Name, home address (not P.O.box), email address, telephone number, as well as a statement of interest and brief description of the artwork. One page maximum – standard type. *A_Cover_JDoe.pdf*
- B. **Image list:** including information on title, size, and media of artwork. *B_imagelist_JDoe.pdf*
- C. **Work samples:** up to 10 images per artist will be reviewed. *C_Worksample1_JDoe.jpg; C_Worksample2_JDoe.jpg, etc.*

Dropbox

Submit your application materials by uploading files to a folder in Dropbox and then sharing that folder with the Madison Arts Commission.

To do so, use the following steps:

1. Go to www.dropbox.com
2. If you don't have a Dropbox account, create a free account at www.dropbox.com
3. Click on the icon of the folder with a green (+), "New folder," at the top of the screen.
4. Title your new folder with your first initial and last name (if applying as individual) or organization.
5. Once this folder has been created, click on it to open it.
6. Click the icon of the paper with a blue arrow, "Upload," at the top of the screen.
7. Click "Choose a file."
8. Select your folder from your computer. Your submission should be 10 MB or smaller. Compress (zip) your folder if needed to meet this requirement.

Sharing your Dropbox folder with MAC

1. Once you have created your new folder and have uploaded all desired files, return to your Dropbox home page (at the top of the page, click the name Dropbox or the blue box icon next to it).
2. Click on the side navigation tab, "Sharing."
3. Click "New shared folder."
4. Click "Existing folder."
5. Select your folder from the list that appears.
6. Type in madisonarts@cityofmadison.com in the invitee field of the next window that appears.
7. Enter your name in the Message field.
8. Uncheck the "Allow members to invite other people" check box.
9. Click "Share folder."
10. If you do not receive acknowledgement from MAC that your grant has been received within 48 hours of submitting via dropbox, please email Madisonarts@cityofMadison.com



Original artwork: Craig Wilson, photo of utility box: Donna Collingwood

Guidelines

Guidelines for Art Selection

The Madison Arts Commission (or Public Art Sub-Committee) will select artists based upon the following considerations:

- The images submitted are high quality, engaging and positive.
- There are no legible logos, words, letters or numbers that could constitute a sign in the right-of-way.
- The design submitted does not promote or advertise a particular community group or organization.
- Artists must be over 18 years of age and consider themselves to be professional artists.
- Artists must reside in the City of Madison.
- Art submitted for consideration should be able to translate well to a utility box wrap, such that parts of the image may be repeated, doubled, flipped, or even removed to accommodate openings, keyholes, protrusions and other general design constraints that come with wrapping a utilitarian traffic utility box that is a working part of the City's Infrastructure.

Typical Utility Box Sizes and Dimensions

The Utility boxes chosen for this program require between approximately 42-62 square feet of coverage depending upon box size and configuration:

- Generalized dimensions of a utility box with a wrapped area of approximately 42 sq ft is 36" wide x 18" deep x 48" high.
- Generalized dimensions of a utility box with a wrapped area of approximately 62 sq ft is 44" wide x 26" deep x 54" high.

Sketch-up files of the 42 sq ft box, as seen in the images below, are available to artists if they contact madisonarts@cityofmadison.com.

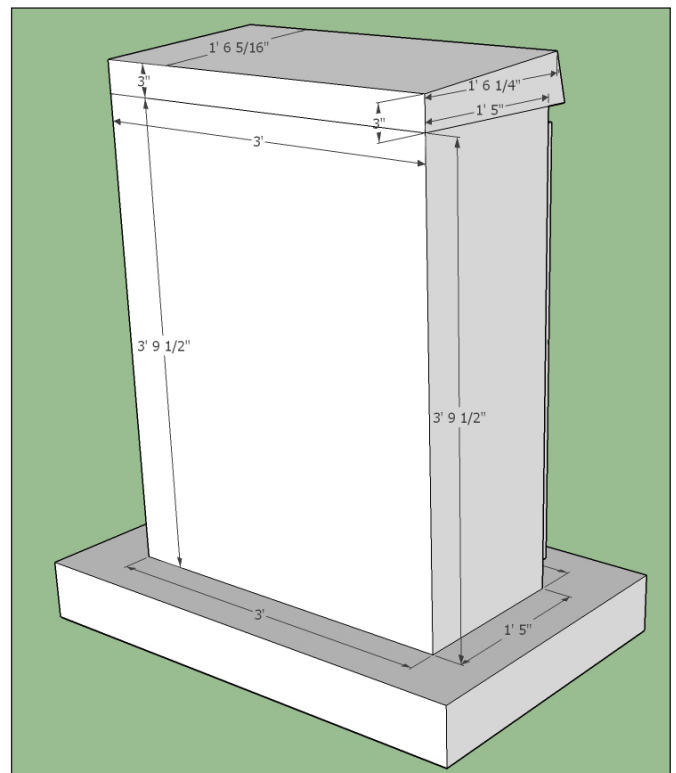
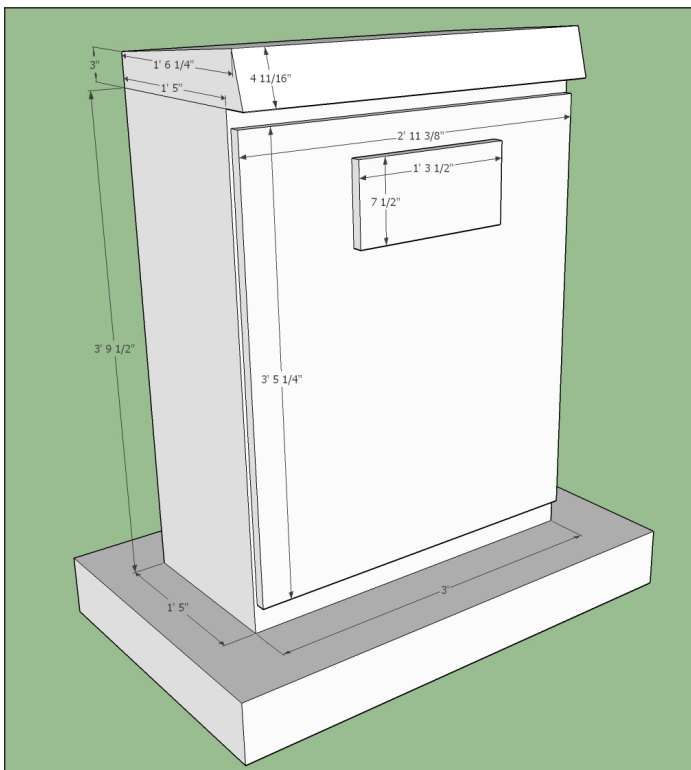

Approximate dimensions of utility boxes. Individual box dimensions vary.

Art License RELEASE for Utility Box Wrap Pilot Project

Name: _____

Address: _____

Phone number: _____

Email address: _____

Title of Art released for use by the City of Madison for the Utility Box Art Wrap Pilot:

Image 1: _____ 6: _____

Image 2: _____ 7: _____

Image 3: _____ 8: _____

Image 4: _____ 9: _____

Image 5: _____ 10: _____

Attach images as Exhibit "A"

I declare and agree as follows:

I am the owner of the images named above and attached to this Release as Exhibit A. I own all intellectual property rights to these images and I am legally authorized to sign this release. I warrant the images are not presently under option and/or have not been purchased by a third party that will object to their use by the City of Madison for this project.

I agree to indemnify, defend and hold the City of Madison, its elected officials, officers and employees free and harmless from any and all claims, damages, costs and liabilities, arising out of any alleged infringement or violation of any intellectual property or other rights, as a result of my submission of the images to the City, or City's duplication and/or use of the images for any purpose associated with the Utility Box Art Wrap project, including promotional use. This indemnity obligation applies to claims of infringement or violation alleged by me, and/or any and all other persons or entities. Any reproduction use by the city will include attribution to the artist listed as "Craig Wilson, Kite Aerial Photography."

I agree to a license fee of \$400 per image to grant the City of Madison a worldwide, non-exclusive, license to use, reproduce, distribute, publish, display these images in any and all media now known or hereafter developed (including, without limitation, print, broadcast, and Internet), for all legitimate business purposes including advertising and promotional activities associated with their use as part of the Utility Box Art Wrap Project, including but not limited to placement and display in the public right-of-way. I declare that the forgoing is true and correct and that I have fully read and understand this Release. I understand that by signing this Release I am giving up important legal rights.

Signed: _____ Date: _____

Print Name: _____